

Pro-Tools

MADE IN THE U.S.A.

3-ROLL BENDER INSTRUCTION SET

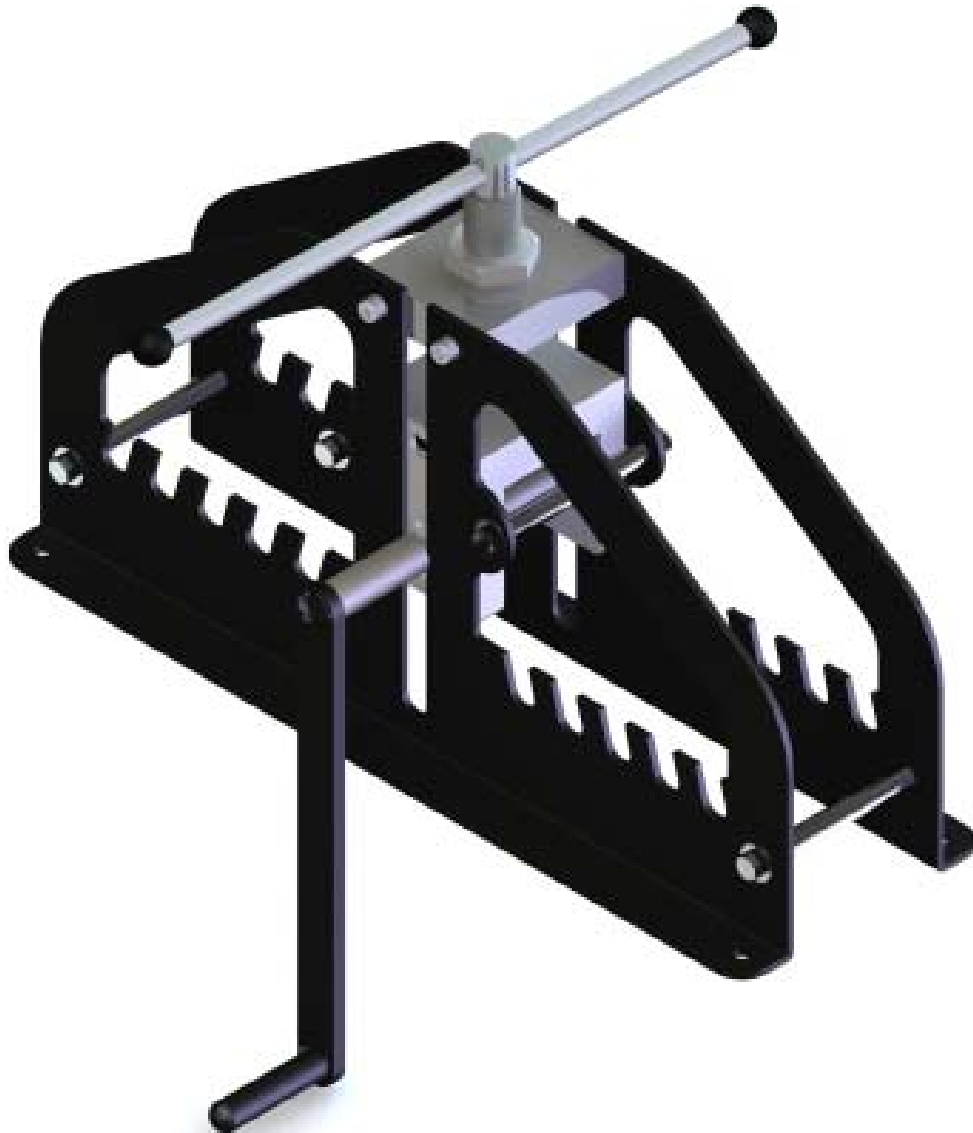

PRO-TOOLS
7616 INDUSTRIAL LANE TAMPA, FLORIDA 33637-6715
813-986-9000 PHONE 813-985-6588 FAX
www.pro-tools.com

3 ROLL BENDER OPERATING INSTRUCTIONS

STEP 1

MARK THE MATERIAL IN THE MIDDLE

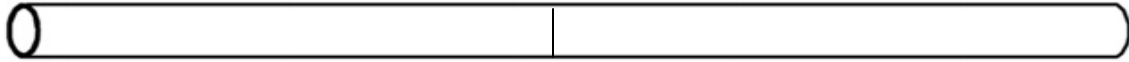

STEP 2

LINE UP THE CENTER OF THE MATERIAL WITH TOP ROLLER THEN TIGHEN 1/2 TURN.

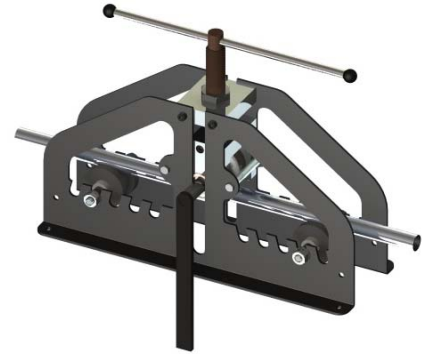

STEP 3

ROLL THE MATERIAL COMPLETELY TO THE RIGHT.

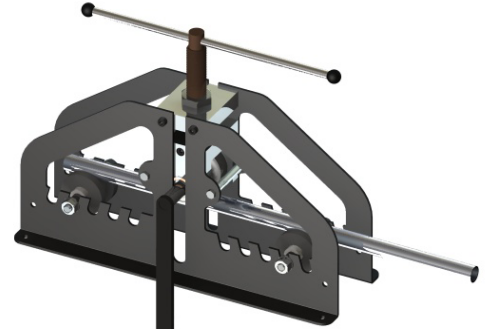

STEP 4

ROLL THE MATERIAL COMPLETELY TO THE LEFT..

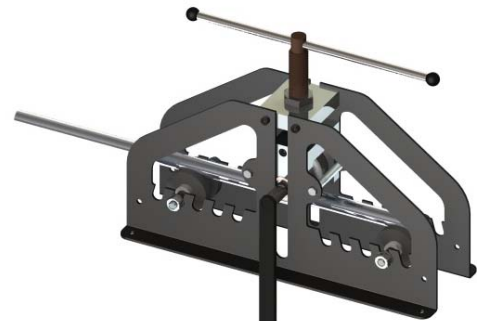

STEP 5

RETURN THE MATERIAL TO THE MIDDLE –TIGHEN THE TOP ROLLER 1/2 TURN. REPEAT THE PROCESS UNTIL DESIRED BEND.

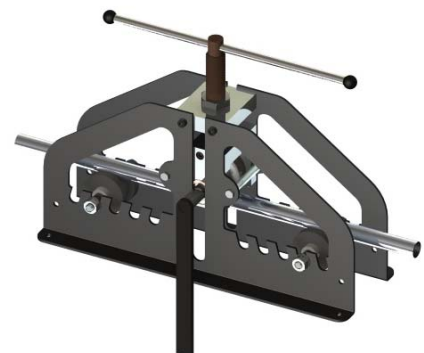

IMPORTANT!! WHEN USING THIS TYPE OF BENDER, IT WILL LEAVE A STRAIGHT PIECE ON EACH END. (THESE ARE CALLED TAILS & WILL NEED TO BE CUT OFF.)

3 ROLL BENDER SET UP INSTRUCTIONS



STEP 1

CHOOSE THE APPROPRIATE ROLLERS TO BE USED FROM THE BEND. GREASE THE BUSHINGS ON BOTH LOWER ROLLERS. TIGHTEN TO ROLLERS DOWN ENOUGH TO HOLD TUBE SNUGG. (THIS ALIGNS ALL 3 ROLLERS!) NOW SET LOCKING COLLARS ON LOWER ROLLERS AS SHOWN BELOW IN (FIGURE A). LOWER ROLLERS MUST ROLL FREE!

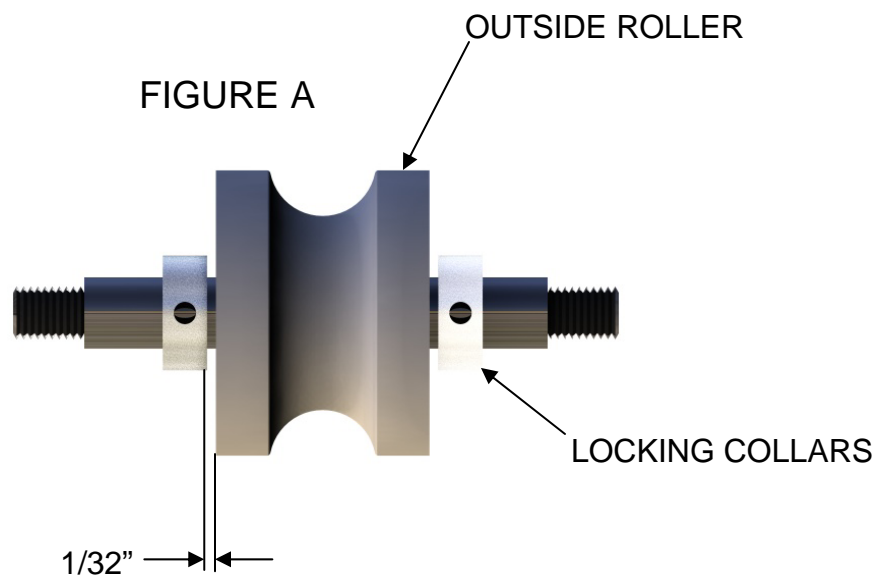

3 ROLL BENDER HELPFUL INFORMATION

ALL TUBING WILL TWIST AS YOU ROLL AN ARCH.

THE LONGER THE TUBE, THE MORE IT WILL TWIST

BELOW IS AN EXPLANATION OF HOW TO HELP STOP THE TWISTING ACTION.

MAKE 2 OF THE FOLLOWING PIECES!

3/8" ALL THREADED ROD
ABOUT 18" LONG

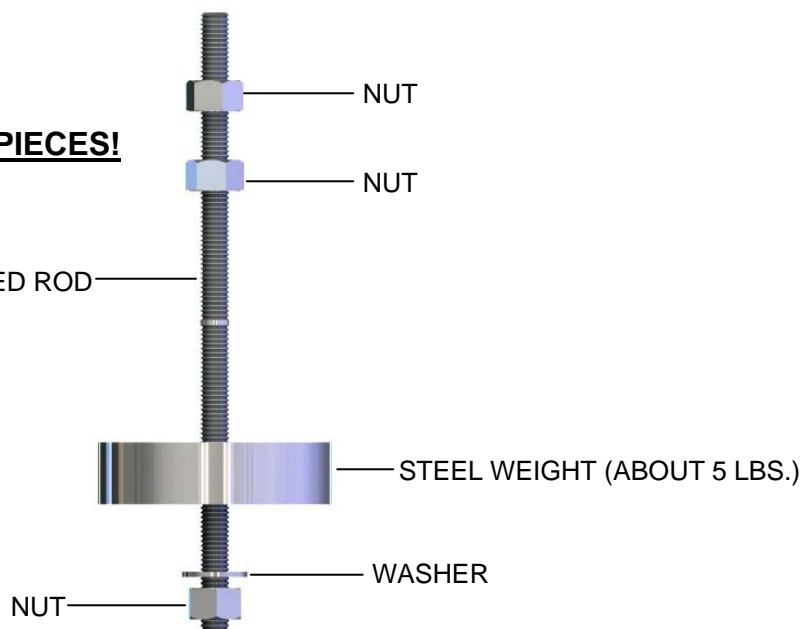

THE WEIGHT HANGING DOWN
SHOULD STOP THE TWISTING.

3 ROLL BENDER

WARRANTY POLICY

ALL PRODUCTS THAT PRO-TOOLS MANUFACTURES CARRY A ONE YEAR GUARANTEE AGAINST DEFECTS IN MATERIAL OR WORKMANSHIP. (PRODUCTS THAT WE SELL BUT DO NOT MAKE ARE COVERED UNDER THAT MANUFACTURING WARRANTY PLAN). ANY TOOLS OR PARTS THAT FAIL ARE 100% COVERED UNDER THE WARRANTY AND WILL BE REPAIRED FREE OF CHARGE (EXCLUDING FREIGHT CHARGES). MISUSE OR ABUSE IS NOT COVERED. SIMPLY CALL AND GET A WARRANTY AUTHORIZATION NUMBER AND IT WILL BE PROMPTLY AND CHEERFULLY TAKEN CARE OF.



SAFETY WARNINGS



- ALWAYS READ AND UNDERSTAND DIRECTIONS THAT ARE INCLUDED WITH ALL PRO-TOOLS EQUIPMENT BEFORE OPERATING. IF DIRECTIONS ARE NOT INCLUDED, CALL PRO-TOOLS IMMEDIATELY.
- USE OF FABRICATION EQUIPMENT MAY PRESENT A PINCH OR CRUSH HAZZARD.
- ALWAYS OPERATE PRO-TOOLS EQUIPMENT WEARING SAFETY EQUIPMENT.
- ALWAYS USE THE CORRECT EQUIPMENT FOR THE PROJECT.
- NEVER USE PIPE BENDING DIES ON A TUBE OR TUBE DIES ON A PIPE.
- KNOW THE MATERIALS YOU ARE USING BEFORE BEGINNING FABRICATION.
- ALWAYS INSPECT EQUIPMENT PRIOR TO USE TO MAKE SURE IT IS IN GOOD WORKING ORDER. IF YOU ARE IN DOUBT, DO NOT USE AND CONTACT PRO-TOOLS.
- NEVER SUBSTITUTE COMPONENTS FROM OTHER EQUIPMENT. MAKE SURE COMPONENTS MATCH.
- NEVER EXCEED THE MANUFACTURER'S SPECIFICATIONS SET BY PRO-TOOLS.
- **ALWAYS LUBRICATE METAL ON METAL PARTS!!!!**



3 ROLL BENDER FAQ's

Q: CAN I BEND COMPLETE CIRCLES?

A: THIS BENDER WILL NOT BEND COMPLETE CIRCLE. IT WILL BEND HALF CIRCLES.

Q: WHAT IS THE LARGEST O.D. TUBING I CAN USE IN IT?

A: WE RECOMMEND 2" ROUND TUBE & 1 1/2 PIPE. IT WILL ALSO BEND 2" SQUARE.

Q: HOW DO I MAKE A REPEAT BEND?

A: PLACE A MARK ON THE SIDE OF THE FRAME BY HANDLE. THIS WILL LET YOU GET KNOW WHEN YOU ARE AT THE RIGHT HEIGHT..

Q: WHAT IS THE THINNEST WALL I CAN USE IN IT?

A: WALL THICKNESS DEPENDS ON A RATIO OF O.D. AND RADIUS AS A RULE OF THUMB ANYTHING ABOVE .065" WILL GIVE YOU A NICE BEND WITHOUT WRINKLES.

Q: WHERE SHOULD I PLACE THE BOTTOM ROLLERS TO START A BEND?

A: YOU TYPICALLY WANT TO START WITH THE ROLLER TO THE FARTHEST POSTION APART AND WORK YOUR WAY IN TO THE DESIRED RADIUS.